

HOT WATER CIRCULATING PUMP

RHC2060-150

*C Series Single Phase Hot
Water Circulator*

CE



Content

- 1、 *Conditions of operation*▶
- 2、 *Points for installation*▶
- 3、 *Maintenance and repair*▶

The C Series Hot Water Circulator

1. Conditions of operation

The pump bearing is lubricated by the pumped water. This pump cannot be run dry for periods exceeding 10 seconds. Do not pump any flammable or corrosive liquids.

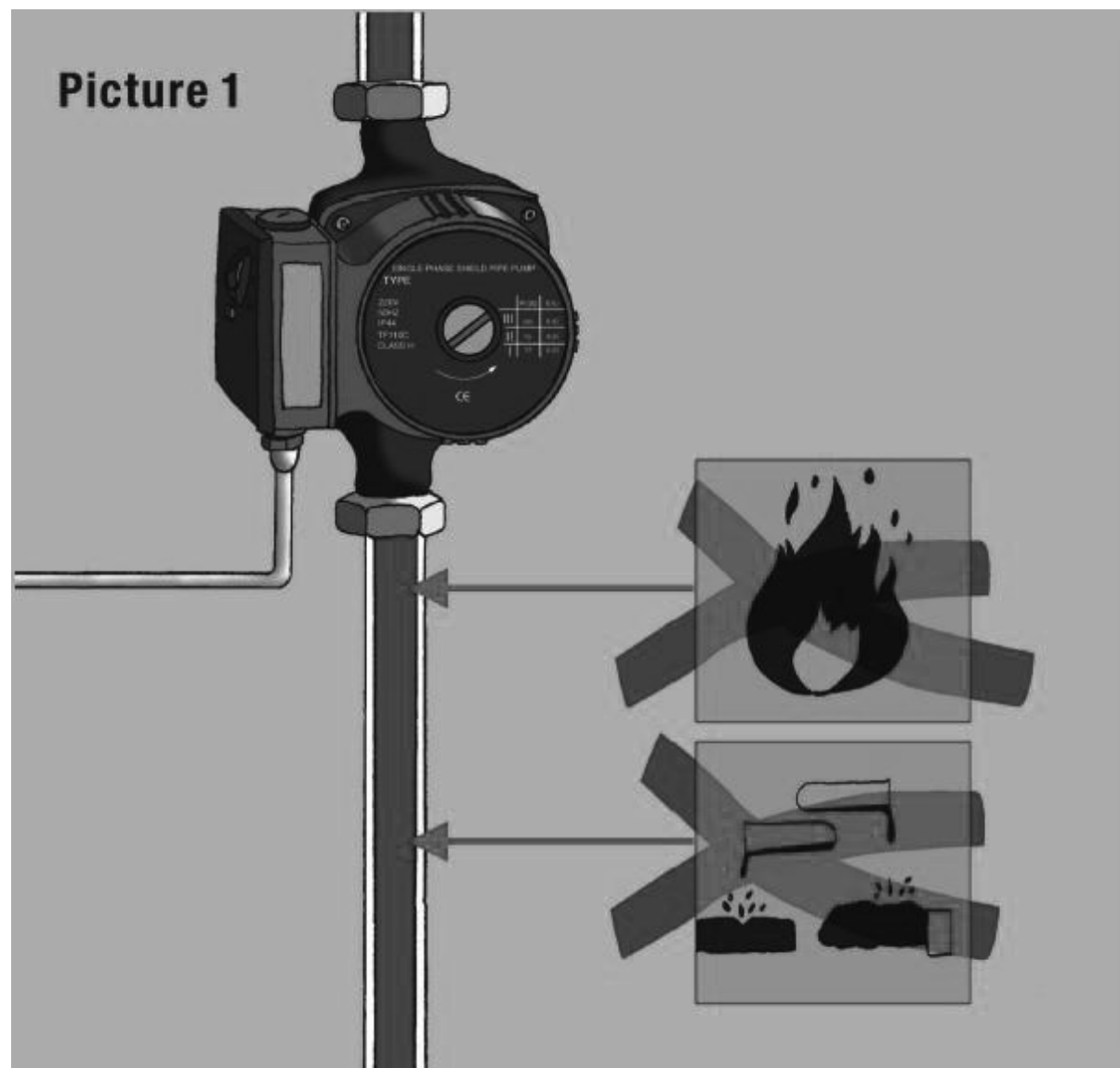

The temperature of the environment must be lower than that of the media.

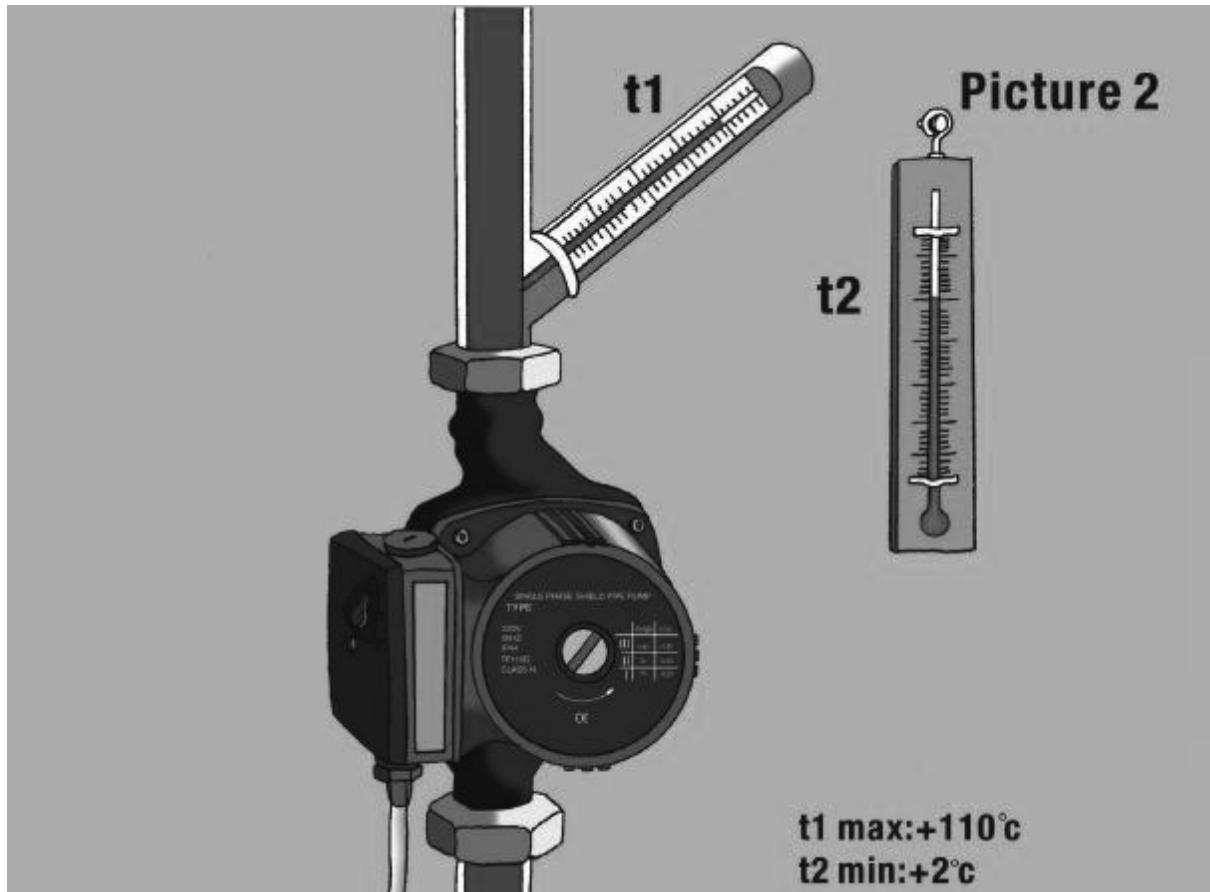

2. Installation

The pump must be installed horizontally.
Pump must be installed as per procedures below (Picture 4)

Picture 3

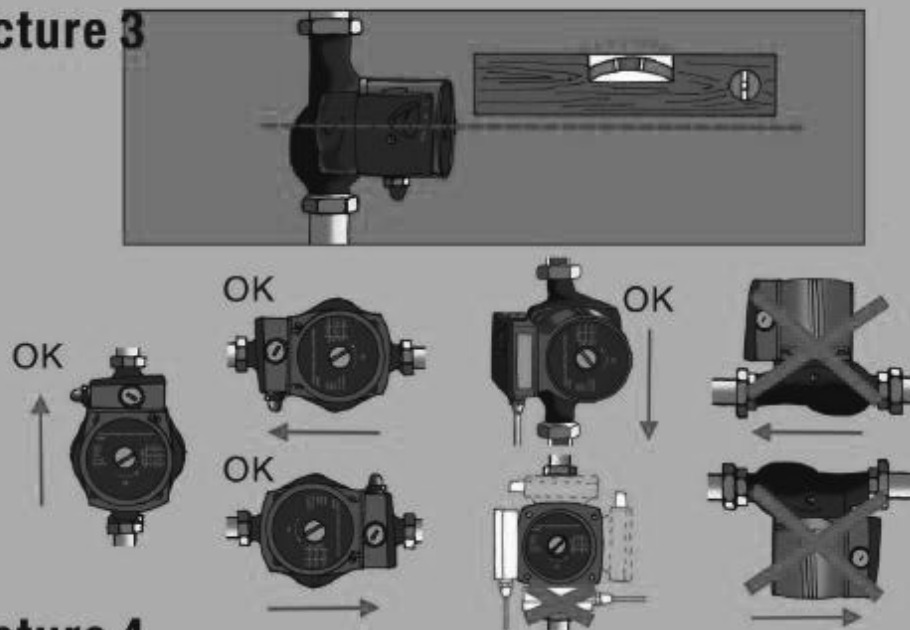

Picture 4

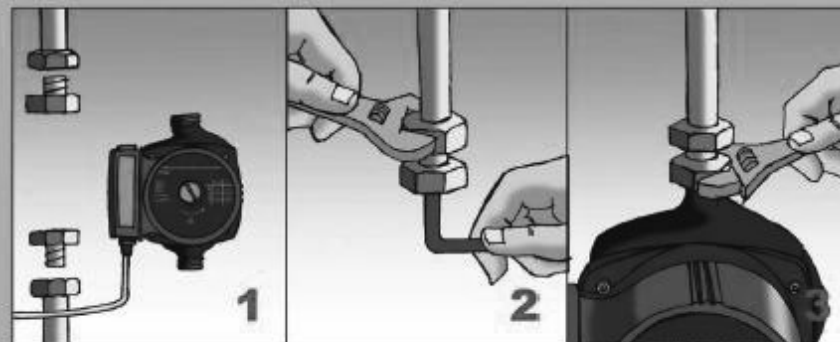

Only qualified and competent tradespeople should attempt installation or electrical work.
Please read all instructions and warnings carefully before installation.

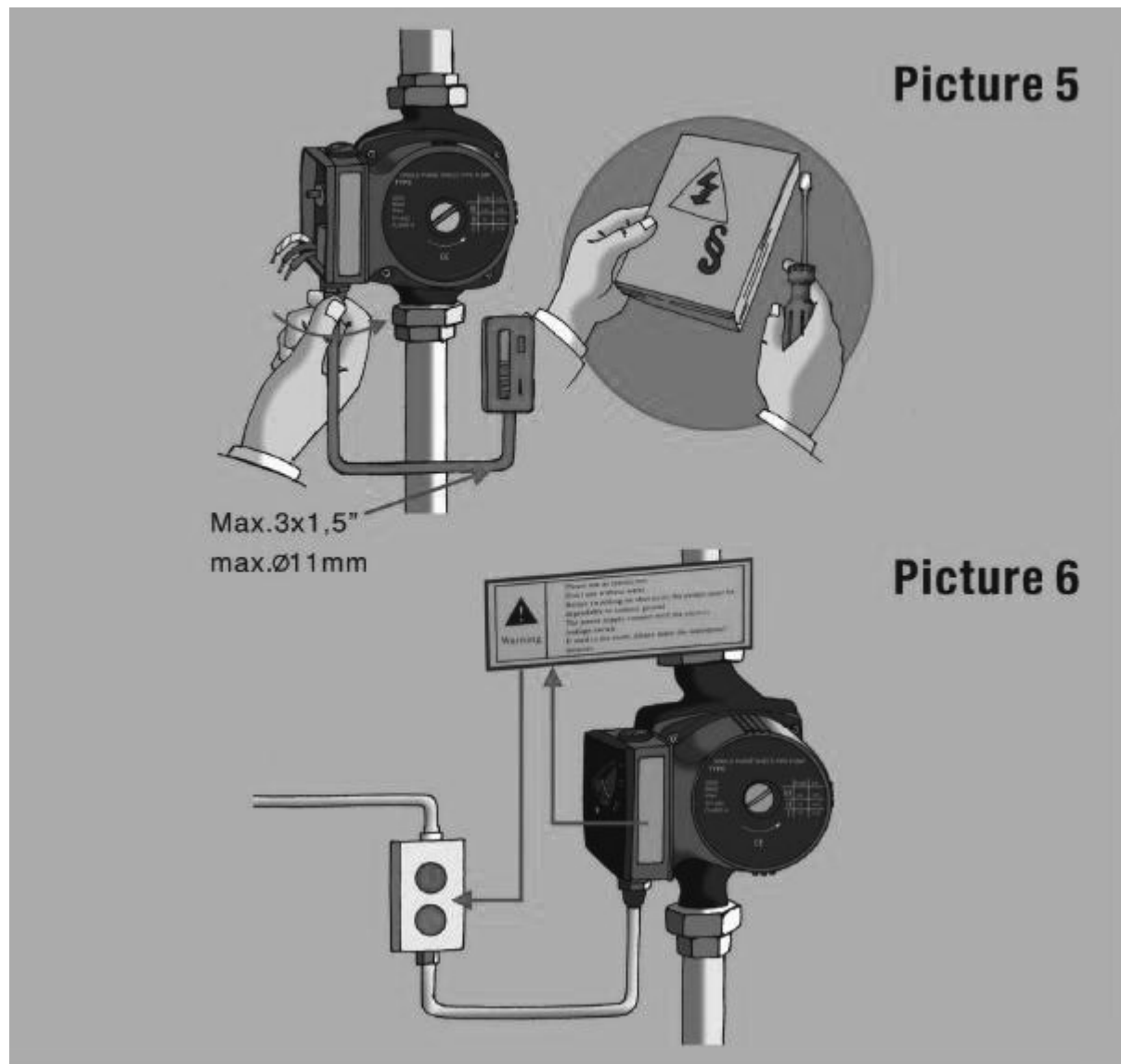

Once installed, bleed air prior to operation as shown in Picture 7

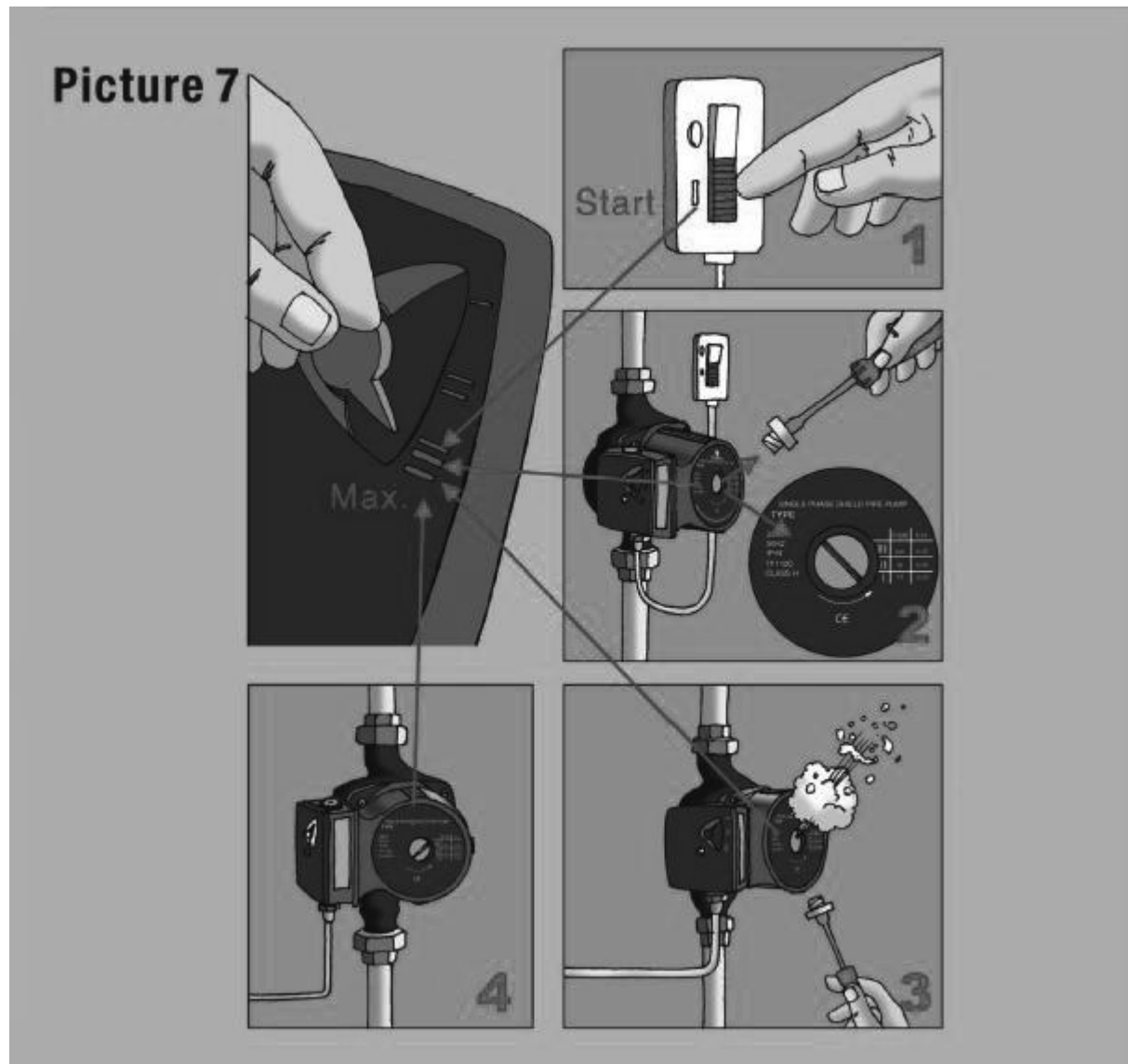

3. Maintenance and repair

Should the power cable need replacement, it must be replaced by a suitably qualified person.

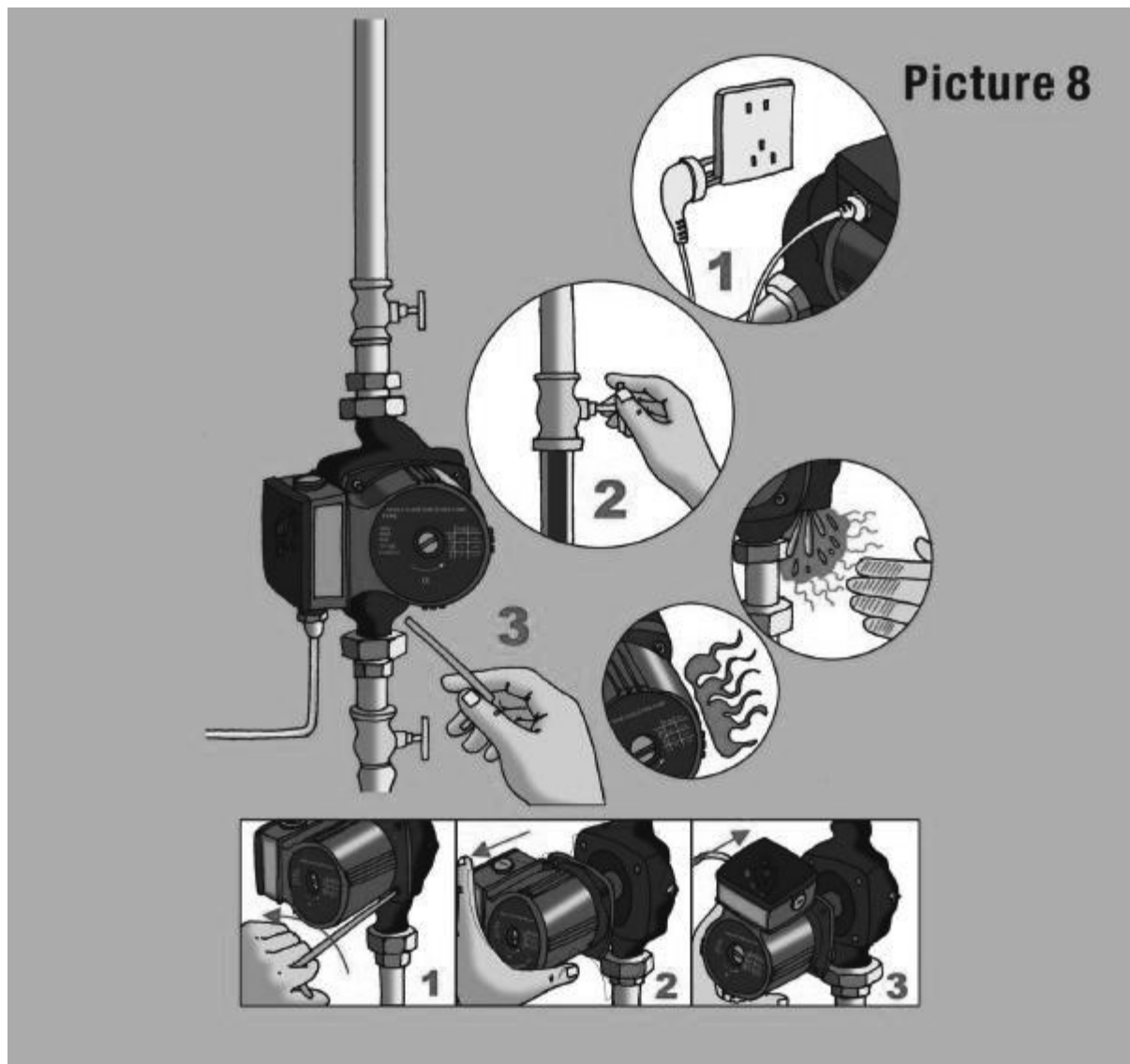

Troubleshooting guide

Fault	Possible Cause	Possible Solution
Pump not starting	Power is not connected correctly	Check fuse and electrical connection
	Faulty Capacitor	Replace Capacitor
	Bearing failure preventing pump from turning	Run at high speed for a short time or loosen rotor using a screwdriver at shaft end
	Blockage in pump due to dirty water	Disconnect the pump and clean
Noise in the system	Pump flow is too high	Change to a lower speed
	Air in the system	Bleed the air out of the system
Noise in the pump	Air in the pump	Bleed the air out of the pump
	Inlet pressure is too low	Increase the inlet pressure. Bleed any air out of the system

CIRCULATING PUMP

C Series Single Phase Hot Water Circulator



WARRANTY CONDITIONS

1. Our goods come with guarantees that cannot be excluded under the Australian Consumer Law. If you are a consumer as defined by the Australian Consumer Law, you are entitled to a replacement or refund for a major failure and for compensation for any other reasonably foreseeable loss or damage. You are also entitled to have the goods repaired or replaced if the goods fail to be of acceptable quality and the failure does not amount to a major failure. If you (the purchaser) do not fall within the meaning of 'consumer' in the Australian Consumer Law the provisions of the Australian Consumer Law will not apply to you. The following conditions form part of the instructions and do not over-ride your statutory rights.
2. 2 Year Warranty against Defects: This warranty covers failure due to manufacturing defects for Hot Water Circulator Pumps purchased from Ascento Group Australia, and used in mainland Australia. We shall replace the pump when we ascertain that the fault is due to manufacturing defect, during the 2 year period from date of purchase. If you require a refund, you must return the item to the original place of purchase.
3. Faults or losses or failure caused due to: Accidents, misuse, lack of maintenance, not following the instructions, damage caused by lightning strike/power surges/spikes/brownouts/operating the pump on power other than 240volts 50Hz mains power - are not covered by warranty.
4. The complete Impeller set (including shaft), Seals and O-rings are all wearing items and therefore are not covered for "normal wear and tear". They are covered by warranty if they are faulty due to a manufacturing defect.
5. Warranty will be void if any tampering or removal of identification labels or electrical cables has occurred, or any non-genuine parts have been fitted, or repairs have been carried out by unqualified persons. No warranty applies for goods sold or used for HIRE or RENT or LEASE
6. The Warranty excludes accidental or deliberate breakages, normal wear and tear, fading or breakdown due to the effect of exposure to sunlight or chemicals or any other external factor that may affect the life of the product.
7. This product is guaranteed as fit for the purpose of pumping CLEAN HOT WATER in normal domestic use. Performance data quoted is generally from test data and is approximate and does not take into account factors in the installation such as loss of pressure and flow due to pipework & pipe-fittings & valves. It is the purchaser's responsibility to ensure that the product is fit for their purpose and of sufficient size & performance for their application.
8. IMPORTANT: No electrical appliances last forever. Therefore ALL installations of pumps must be constructed to allow the owner to easily remove the pump for servicing, and to easily remove the pump for replacement, warranty replacement or upgrading. Warranty replacement does not include costs of removal and re-installation as we have no control over the method of installation.
9. Before installing or servicing disconnect from the power supply.
10. The Pump MUST NOT be installed in any manner that if it were to leak, or fail to work, that it would cause damage or loss to property or persons. It MUST be installed in a well-ventilated and drained area. All warranty is void if this condition is not heeded and no liability can be accepted in the case of damage or loss caused by failing to comply with this condition.
11. The Pump must be correctly earthed and connected to a circuit with an integral RCD (safety switch) in the circuit breaker, in accordance with the Electrical Regulations or Standards that are applicable.
12. Pumps used in SUITABLE commercial or industrial applications are covered by a replacement warranty only, when proved to have a manufacturing defect that has caused the pump to fail. No warranty applies when used in unsuitable applications.
15. If an exact replacement is not available, the closest equivalent product will be supplied at our discretion.
16. This warranty does not exclude any non-excludable rights according to Australian Law. However any condition that is made void by Australian Law does not void the remaining conditions, which shall stand unaltered.

IMPORTANT

NOTICE

This pump is not suitable for outdoor use - it must be protected from the weather by way of a weatherproof enclosure. Failure to do so voids the warranty.