



MULTISTAGE SUBMERSIBLE  
**PRESSURE PUMP**

INSTRUCTION MANUAL

**MODEL:** RSME34 | RSME68 | RSME80  
**CODE:** 21125 | 21149 | 21132

**\*\*PLEASE LEAVE THIS GUIDE IN A SAFE PLACE FOR THE OWNER\*\***

**INSTALLATION GUIDELINES**

Please read and follow the instructions which are to be read in conjunction with the diagrams on the following pages. Ensure all installations are in compliance with any relevant Australian Standards, this is the installers responsibility. Warranty covers manufacturing defects of the pump; it does not include faults in the installation. Note that all warranty is voided if the instructions are not followed. Use for CLEAN FRESH WATER only.

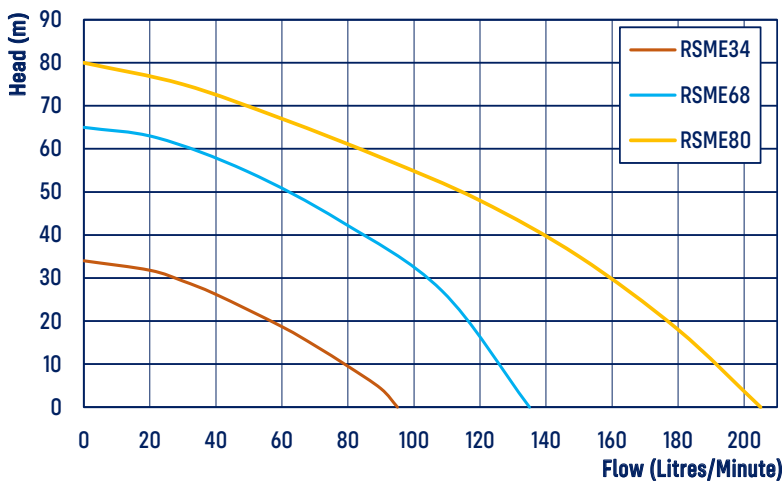

CODE	MODEL	POWER 240V				RATED		MAXIMUM		MAX IMMERSION DEPTH (M)	CABLE LENGTH (M)	OUTLET (MM)	SIZE DØ X H (MM)
		AMPS	P1 (kW)	P2 (kW)	HP	FLOW (L/MIN)	HEAD (M)	FLOW (L/MIN)	HEAD (M)				
21125	RSME34	4.2	0.95	0.55	0.75	48	23	95	34	17	20	25	127X452
21149	RSME68	8.5	1.8	1.2	1.6	67.5	49	135	65	17	20	32	127x649
21132	RSME80	12.5	2.88	2.2	3	100	49.3	206	77	17	20	40	152x561

NOTE: Performance data quoted is generally from test data and does not take into account factors in the installation such as loss of pressure and flow due to pipework & pipe-fittings & valves.

## IMPORTANT INSTALLATION & WARRANTY CONDITIONS

1. If the premises does not have an RCD (safety switch), DO NOT INSTALL.
2. If the pump is simply being used to transfer water it can be controlled using the float switch to turn it off when the water level is low.
3. If it is being used for constant water supply (for example as house or irrigation supply) it must be coupled with a suitable control to start & stop it – either a REEFE Pump Controller; Pressure Switch, Tank & Gauge; or Variable Speed Controller – that has been suitably sized by a competent person. For all installations for constant water supply, a Pressure Tank must be included in the installation.
4. The pump must be easily accessible for servicing or repair.
5. Ensure the connection to the pump INSIDE the tank is VERY robust - you must use 15 wraps of thread-seal tape on the MI fitting to prevent the pump rotating itself off the fitting. (This will lead to pump cycling which is not covered by warranty).
6. If the pump has a float switch, ensure it CANNOT get stuck on the side of the tank or under baffles or similar - warranty service does not cover this situation.
7. Include a Barrel-Union and Ball Valve external of the tank to allow easy servicing or repair. A Barrel-Union must be fitted external of the tank to allow easy servicing of the pump, install it after the elbow to avoid it twisting loose from the pump starting & stopping.
8. For underground tanks, the installation must be designed and constructed to allow easy access, for servicing or repair of the pump, warranty does not include costs of digging up gardens etc!
9. All Electrical Wiring must be in accordance with Australian Standards, no warranty applies if not.
10. A “First-flush-diverter” or similar device must be installed, and /or a filter screen through which all the incoming water passes before entering the tank, to prevent debris from entering the tank.
11. Warning: when lowering Pump into Rainwater Tank: Use the rope to lower the pump into the tank. DO NOT USE THE POWER CABLE. Using the power cable will lead to pump failure which will not be covered by warranty, all costs will be borne by the installer.
12. Install the pump UPRIGHT in the tank. The length of the pump must be vertical, it must not be on an angle off vertical, it must not be horizontal.
13. DO NOT install it in such a manner that it would require a person to get inside the tank to remove/repair it.
14. You MUST use 25mm or larger suitable PVC pipe connected to the discharge of the pump. DO NOT CONNECT COPPER or GALV PIPE or less than 25mm ID PVC PIPE to this pump.
15. Glue or other substances dripped inside the pump voids warranty. Do NOT fit threaded fitting to the pump then glue pipe to that fitting as glue will drip inside the pump. Glue the fitting and allow it to dry BEFORE attaching the threaded fitting to the pump. NOTE: If the fitting leaks, it will cause cycling of the pump, this is not warranty – this is the installer’s responsibility.
16. Ensure that the pump will not knock against the side of the tank during start-up, or operation or stopping.
17. No electrical appliance lasts forever - the pump must be easily accessible for repair or servicing - if the rainwater tank is installed under eaves, or under a deck or any other structure, ensure the pump can be easily removed.
18. An Isolation valve must be fitted (ball-valve or gate-valve) in the discharge pipework
19. It is the INSTALLERS responsibility to check the pumps operation prior to leaving the site CHECK ALL CONNECTIONS: Ensure all fittings and joints are watertight and airtight. Leaks will cause the pump to cycle on & off continuously, this is not a fault of the pump.
20. All Electrical Wiring & Power Outlet & Cable protection must be in accordance with applicable Australian Standards. We recommend a separate circuit.
21. IRRIGATION USE - MANDATORY REQUIREMENTS FOR ALL INSTALLATIONS: For any installation of pumps supplying irrigation, you must fit an 18L or larger pressure tank. Tank Pressure Settings: 70% of maximum head pressure of pump (displayed in performance data table)
22. Some air may be pumped when the tank is low in water – this is not a fault it is normal operation.
23. NO RCD/SAFETY SWITCH? DO NOT INSTALL PUMPS!



**CORRECT INSTALLATION  
WITH PRESSURE CONTROLLER**

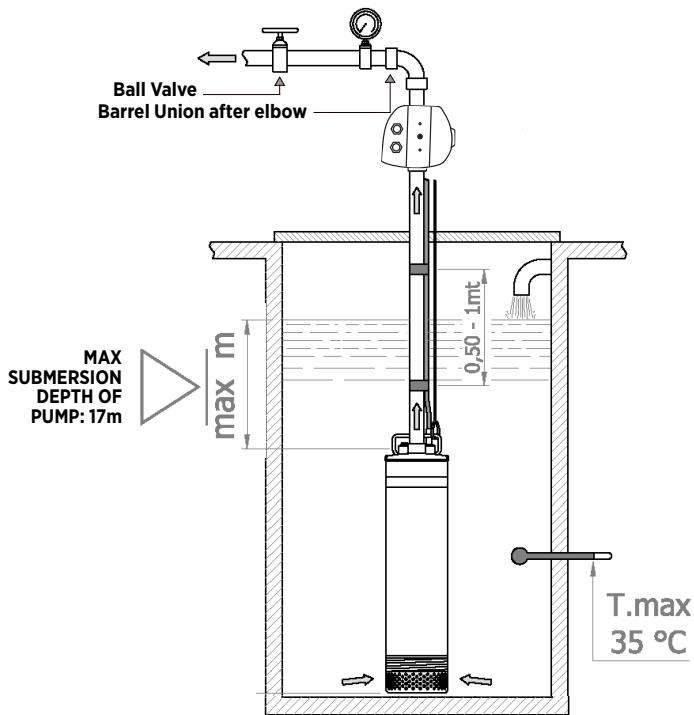

**CORRECT INSTALLATION  
WITH PRESSURE TANK SWITCH GAUGE & TEE**

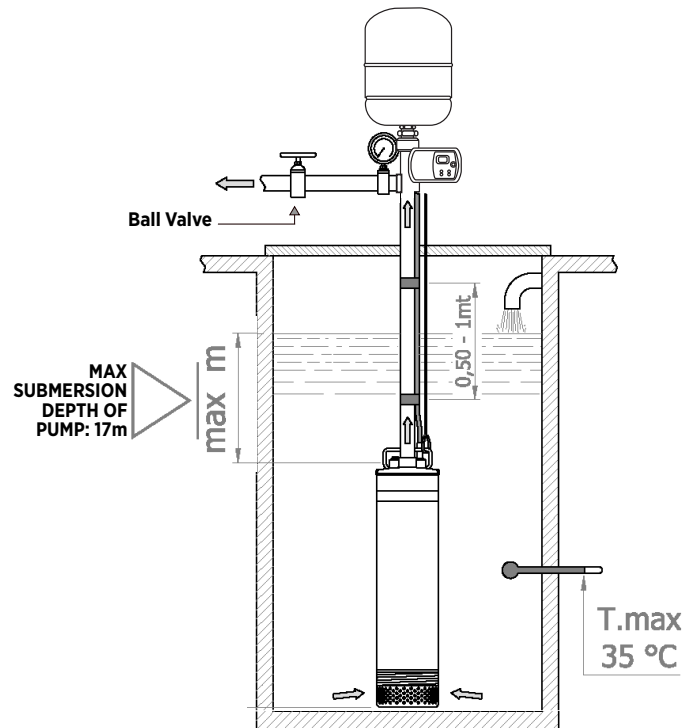

**WARNING**

**GLUE DRIPPED INSIDE PUMP VOIDS WARRANTY**

**ENSURE STRONG CONNECTION SO PUMP CONNECTION DOES NOT WORK LOOSE USE 15+ WRAPS OF THREAD SEAL TAPE ON MI FITTING**



**CORRECT INSTALLATION**

**IMPORTANT! ENSURE THE PUMP IS SIZED CORRECTLY FOR THE JOB. TOO SMALL = LOW PERFORMANCE AND MAY USE EXCESS POWER, AND/OR OVERHEAT THE MOTOR AND/OR CAUSE PREMATURE FAILURE AND/OR NOT PUMP ANY WATER. THIS IS NOT A WARRANTY FAULT IF THIS OCCURS.**

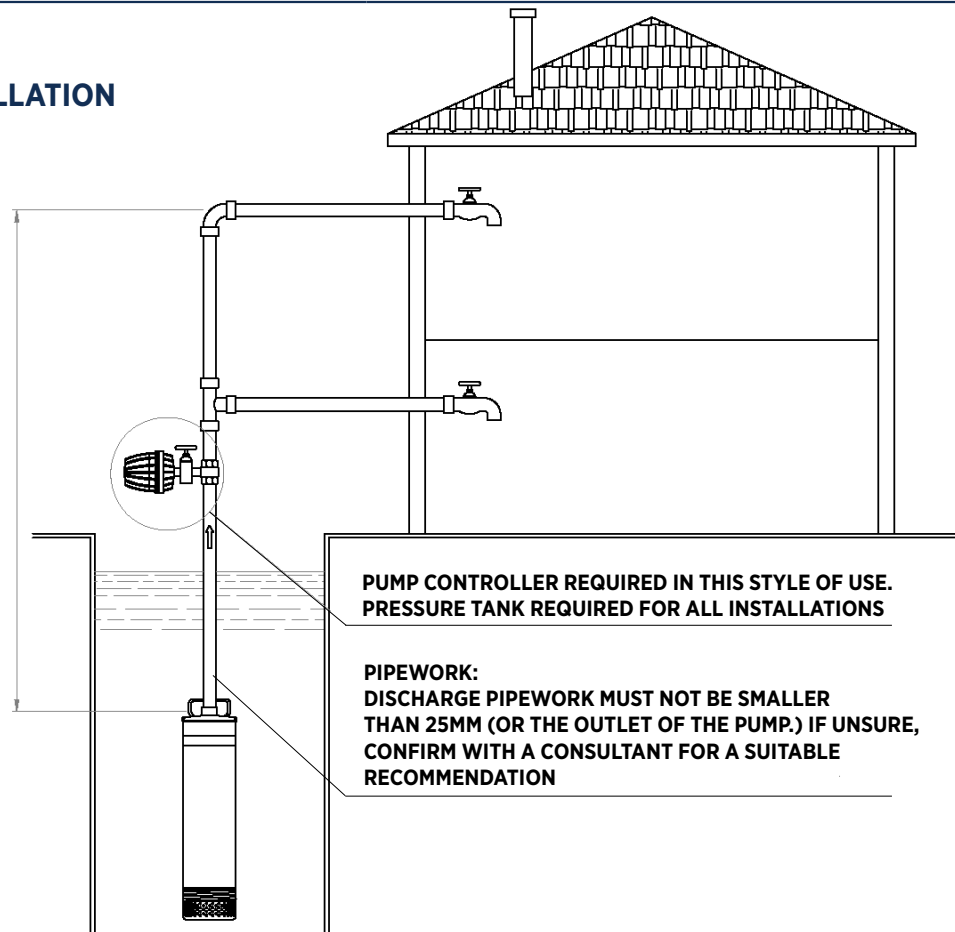

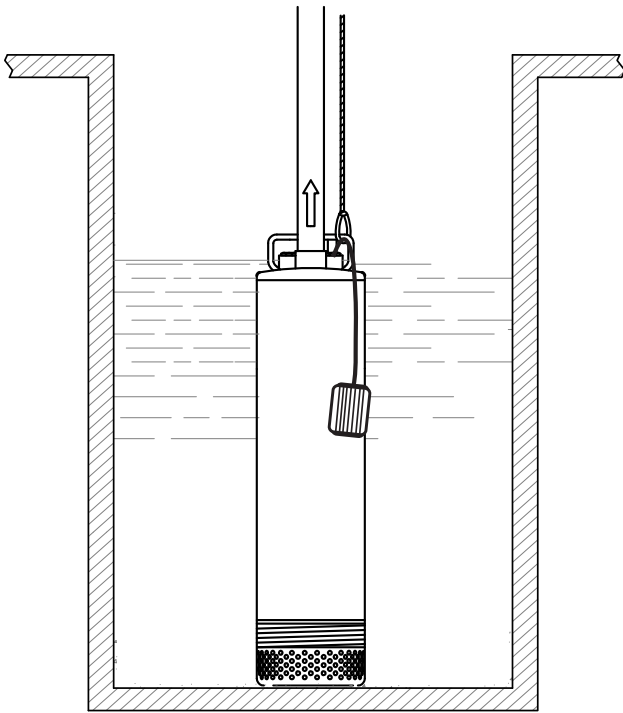

**PUMP SHOULD BE AT THE BOTTOM OF THE TANK**

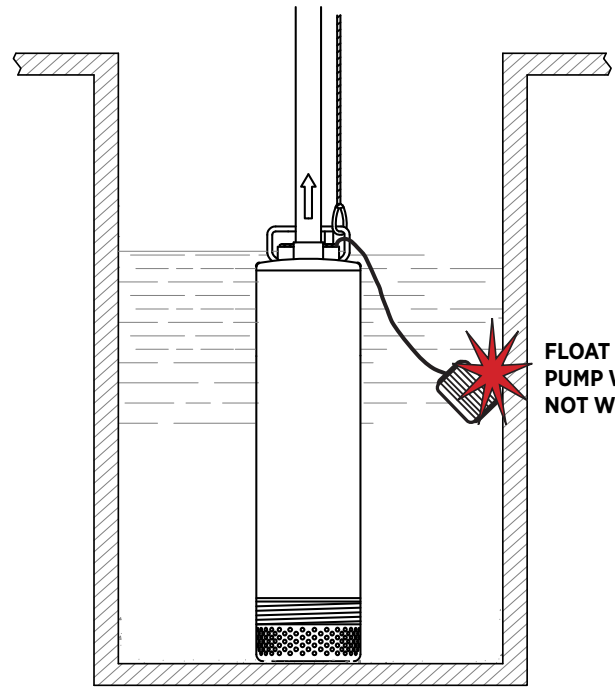

**FLOAT STUCK  
PUMP WILL  
NOT WORK**

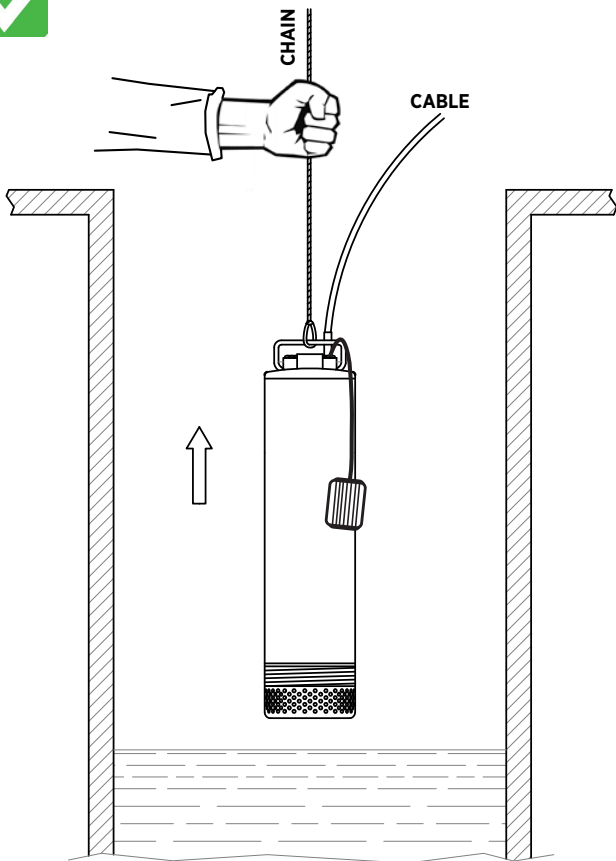

**LIFT THE PUMP USING A CHAIN/ROPE THROUGH THE HANDLE**

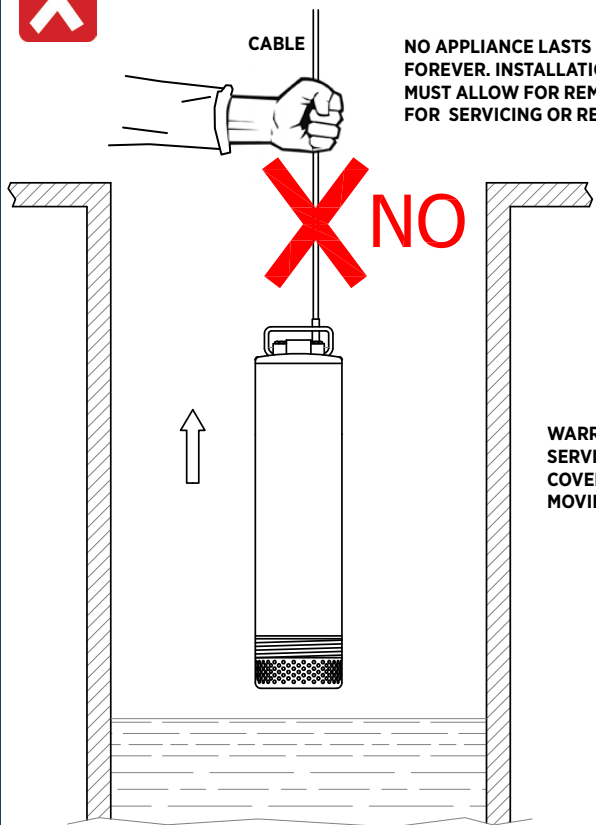

**NO APPLIANCE LASTS  
FOREVER. INSTALLATION  
MUST ALLOW FOR REMOVAL  
FOR SERVICING OR REPAIRS**

**WARRANTY  
SERVICE DOES NOT  
COVER COST OF  
MOVING TANK**

**NEVER LIFT THE PUMP FROM THE CABLE**

## FURTHER INFORMATION FOR THE INSTALLER

1. Try to minimise the amount of bends in the delivery pipe. Pipes of insufficient diameter connected to the pump will severely restrict the performance of the pump, cause the pump to use more electricity, and may cause the pump to cycle on/off frequently, this is not covered by warranty as it is caused by the installer. If the user requires the best possible pressure from the pump, the recommendation is for the delivery pipe to be 25mm ID for the majority of the pipeline.
2. IRRIGATION USE TANK PRESSURE SETTING: 70% of maximum head pump pressure (displayed in performance data table)
3. During installing or servicing disconnect the pump from the power supply.
4. Ball-valves or gate-valves must be fitted on the discharge, and the Town-water backup supply where fitted. An additional Check-valve must be fitted outside of the tank (not on the pump) where it is used with a Town-water backup system, but only if the Town-Water backup system does not have a built-in check-valve on the Rainwater connection. This instruction is a condition of warranty; all warranty is void if this instruction is not followed. The pump must be installed to comply with applicable Plumbing Regulations.
5. Do not remove the base off the pump as this will then cause it to take in solids or sludge which will lead to reduced performance and ultimately, failure, which is not covered by the warranty. This pump is not to be used as your sole water supply. For critical applications where loss of water supply could cause serious consequences, use a DUAL PUMP System so you have a back up water supply or use a TOWN-WATER BACK-UP SYSTEM. This pump is not designed for Fire Fighting purposes.
6. IMPORTANT: This pump MUST NOT be installed in any manner that if it were to fail that it would cause damage or loss to property or persons. It MUST be installed in a well-ventilated and drained area.
7. DO NOT lower or lift the pump using the power cable – use nylon rope to lower or lift the pump in and out of the tank.
8. ELECTRICAL SUPPLY: (a) Plugging into existing outlets that have other appliances connected may cause low voltage supply to the motor, causing the circuit-breaker to trip, tripping of motor overload, or burnt out motor, which will not be covered by the Warranty. RECCOMENDATION: a dedicated electrical circuit with a combination circuit breaker & safety switch be installed for ALL pump types. This is important in order to prevent inconvenience to the resident, is an additional safety precaution, and also helps to avoid un-necessary call-outs after hours and on weekends. (b) Surge Protection - We recommend that a surge protector is used to protect the electronics of this pump, as damage due to power surges is not covered by the Warranty. (c) The Power Outlet must be in easy reach for the owner to access, and must be in a sheltered area to prevent the plug and power outlet getting wet from rain or snow or garden irrigation or the roof gutters overflowing, etc. VOLTAGE of power supply must match the voltage of the pump, 230-240Volt from MAINS supply only. Do not use with generator power, unless it is a high quality inverter type.
9. FLOAT SWITCH: When the water level drops below about half of the height of the pump it will turn off the power to the pump, the pump will not restart until the tank fills up again.
10. WARNING: these pumps are not designed for and must not be installed in locations classified as hazardous.
11. THE FOLLOWING MAY CAUSE SEVERE DAMAGE TO THE PUMP AND WILL VOID WARRANTY; (a) Using an extension cord to power the pump. (b) Cutting the earth pin off the plug or using an adapter fitting or double adapter. (c) Working on the pump while connected to the power supply. (d) Removing motor housing, or disassembling the pump housing, except by a qualified technician (e) Pumping chemicals or corrosive liquids or flammable liquids or dirty water or waste water or contaminated water. (g) Pumping hot liquids (Exceeding 35°C) (h) Using a generator for power supply – see 27
12. OVERLOAD PROTECTION This pump has a built in thermal protection switch. The pump stops if a high-temperature condition occurs. The motor restarts automatically after it has cooled down when the built in thermal protector resets itself. Or you may need to turn the power off and on again to reset it. If this problem reoccurs - check for possible causes – refer to trouble-shooting.
13. IMPORTANT NOTES (a) Do not switch the pump on and off frequently, as this will cause damage to the electronics and void warranty. (b) If there is insufficient water, the motor will stop. (c) If the pump is idle for a long period of time or in very low temperature, the water should be drained to avoid damage to the pump and/or stagnation of water.
14. FLOAT SWITCH – the float turns the power OFF to the pump when water level is low, it will not turn back ON until the tank fills up again.
15. All warranty is voided if these instructions are not heeded and no liability can be accepted in the case of damage or loss caused by failing to comply with all the instructions.

## **DANGER!**

Keep the pump equipment protected from interference by children, infirm persons, incompetent persons, pets and wildlife.

## **WARNING!**

This pump is designed for clean fresh water only, in non-hazardous locations.

It must NOT be used as a continuous duty fountain pump, or to pump dirty water, or to pump liquids other than clean water.

## **WARNING!**

**It must never be used in bodies of water used for swimming or bathing or in animal drinking containers.**

## **TROUBLESHOOTING CHECKLIST**

Check the following before requesting service or repair. A call out fee and labour cost may apply to field services.

## **PROBLEMS & POSSIBLE CAUSES:**

**1. Pump Operates When Water Tank Is Empty:** This would indicate that the float switch of the pump is stuck in the up position > turn the pump off and inspect inside the tank > rectify the cause of the float being stuck. NOTE (a) tank level indicators are not always accurate!! Check inside the tank to be sure of the water level. NOTE (b) If the pump has been operating dry for more than a few minutes it is highly likely that the seals are irreparably damaged and when the tank refills with water the pump will fail / trip the safety switch. This is of course not a product fault, it is not warranty.

### **2. Pump does not run or motor runs for a short time, then stops:**

**i.** Circuit breaker or Safety Switch is off or fuse has blown > in a SAFE manner investigate why this has occurred, by process of elimination > do not assume it is the pump > if you cannot do this safely, have a licenced Electrician check and rectify it.

**ii.** Water level in the tank is too low > Top up or use alternative supply > or turn pump off until the tank fills

**iii.** Electrical components of the controller or power point have been flooded > in a SAFE manner investigate why this has occurred, by process of elimination > do not assume the pump is faulty > if you cannot do this safely, have a licenced Electrician check and rectify it.

**iv.** Pump plug is not connected properly, or has been flooded or wet > Isolate power at main switch, remove plug & allow to dry. If the problem continues, contact a licenced electrician to check the cause.

**v.** Pump has an air-lock > Start and stop several times by turning the power off, wait 30 seconds, and turn on again, repeat if necessary.

**vi.** If all of the above are OK, the pump might have overheated and triggered the thermal overload switch > Turn it off and wait 30 minutes for it to cool down and turn it on again > If the pump does not operate normally, investigate why, it might be blocked with debris > turn off power, remove pump from tank, flush clean and re-assemble.

### **3. Pump runs but does not deliver water or only a small amount of water:**

**i.** Water filters on the discharge (if fitted) are clogged > check / clean /replace the cartridges

**ii.** Check valve is installed backwards, arrow on valve should point in direction of flow > have the installer fix this.

**iii.** Discharge shut-off valve/ball-valve / gate-valve may be closed > open the valve.

**iv.** Impeller or volute openings are fully or partially clogged or it might be blocked with debris > disconnect from the power supply, and if you are competent to do so, disassemble the pump and clean. If not, have a pump technician do it for you.

**v.** Pump is air-locked > Start and stop several times by turning it on and off with 20 seconds between.

**vi.** Vertical pumping distance is too high - Reduce distance or upgrade to a larger pump.

**vii.** Tank too low water level > Check the water level by looking inside the tank (Tank level indicators can be wrong)

### **4. Pump runs and does not stop or runs when no taps are in use:**

**i.** In most cases this situation is due to a leak in the pipework or leaking toilet cisterns or an underground pipe leak (wet soil, muddy, grass growing well!) > it is not a pump fault > ascertain by process of elimination what is leaking > turn off the isolation valve on the discharge pipework > does the pump stop = the leak is further down the line > if not then check toilets etc > the only sure way to check toilet cisterns is to turn them off at the stopcock which is usually under the cistern as most of them will not run into the pan.

**ii.** The pump has come loose off the pipe inside the tank > look inside the tank with a torch to check this > if the water is above the pump you will need to lower the water level so you can check this properly > if there is water leaking inside the tank have the original installer return and rectify this, it is not covered by the pump warranty as it is an installation issue.

iii. There is a leak in the pipework inside the tank > reduce the water level in the tank until you can see the top of the pump open a tap to a slow dribble so the pump starts, then remove the leaf-trap off the tank and use a bright torch to inspect the pipework inside the tank to see if it is leaking – even a slight leak will cause the pump to cycle on/off/on/off > if there is water leaking inside the tank have the original installer return and rectify this, it is not covered by the pump warranty as it is an installation issue.

**5. Pump not pumping properly:**

- i. Too high head or pump under specified > Check specifications.
- ii. Too low water level > Check the water level in the tank, tank level indicators are not always accurate

**6. Safety Switch (RCD) or Circuit Breaker trips when the pump starts**

- i. Circuit could be overloaded with too many appliances connected to it > disconnect appliances one by one and discover by process of elimination which appliance is causing the issue and plug it into a different circuit > if unable to ascertain this, or unable to use a different circuit easily, contact a licenced electrician to install additional circuit
- ii. Power plug is wet > refer 2.3
- iii. If none of the above, the Motor may be defective > have it checked by a qualified technician

**If you have checked all the above trouble shooting points and fail to rectify the problem, have the pump checked by an experienced pump technician.**

**WARNING! ELECTRICAL PRECAUTIONS**

Before servicing a pump, always shut off the power supply and then make sure you are not standing in water and that there is no risk of electrical shock.

If the pump is direct-wired to the electrical circuit, contact a qualified licensed electrician to disconnect it before attempting any repairs or servicing.

**DO NOT ATTEMPT ELECTRICAL REPAIRS OF ANY SORT UNLESS YOU ARE A LICENSED ELECTRICIAN**

PARTS: Enquire for parts availability as most are not stocked. Repair should not be attempted by unqualified persons and consideration should be given to the economics of attempting repair.

**INSTALLATION CHECKLIST: MUST BE FILLED IN FOR A WARRANTY TO APPLY**

Installer name:.....Phone Number:.....

Qualification:.....(write Owner if applicable)

If installed by a Plumber or Electrician - Licence No: .....

Installation Address: .....

Tick the boxes as the item is completed/correct, put n/a if not applicable

- The Pump is being used for an appropriate purpose for which it is intended, according to the instructions
- The Power Circuit the Pump is connected to is RCD (Safety Switch) Protected
- All swarf has been removed from the tank after cutting openings etc.
- Barrel Unions are fitted on the pipe connections for easy removal & replacement
- Pipe is sized appropriately for the application (diameter and length)
- The installation is constructed so the pump can be easily removed or replaced.
- If applicable: The pump is installed in accordance with National & Local Plumbing Regulations
- The Electrical Supply cable of the pump is plugged into a Power Outlet that is in accordance with the current standard of Electrical Safety Regulations AS/NZS 3000 – or the pump has been wired directly to the power circuit by a Licenced Electrician, with a suitable isolation switch in an easily accessible area.
- The Pump has been started, tested, and operates correctly.
- The pipes and connections and the barrel-union on the pump, and toilet cisterns (if connected) have been checked for leaks
- The pump has a suitable control to start & stop it – either Pressure Switch or Pump Controller or VSD Controller – that has been sized suitably by a competent person.

**WARRANTY RECORD - FILL IN AND RETAIN THIS WITH YOUR ORIGINAL PURCHASE RECEIPT – DO NOT SEND IT TO US – WE WILL REQUIRE A COPY OF THIS RECORD IF THERE IS EVER A WARRANTY CLAIM.**

PURCHASER NAME:.....PHONE NO.....

DATE OF PURCHASE...../...../..... DEALER/STORE NAME.....

DEALER SUBURB/TOWN.....PHONE NO.....

BRAND & MODEL NUMBER OF PUMP.....

SERIAL/BATCH NO.....



## WARRANTY CONDITIONS

1. Our goods come with guarantees that cannot be excluded under the Australian Consumer Law. If you are a consumer as defined by the Australian Consumer Law, you are entitled to a replacement or refund for a major failure and for compensation for any other reasonably foreseeable loss or damage. You are also entitled to have the goods repaired or replaced if the goods fail to be of acceptable quality and the failure does not amount to a major failure. The following conditions form part of the instructions and do not over-ride your statutory rights.
2. This warranty against defects covers failure due to manufacturing defects within the period as stated in the table below from the date of original purchase, for SUBMERSIBLE or EXTERNAL CONSTANT PRESSURE PUMPS and RAIN-TO-MAINS SYSTEMS, supplied by ASCENTO GROUP AUSTRALIA that are purchased and used in mainland Australia. In the case of a failure caused by a defect in the product, within the specified period from the date of original purchase, you can return it to the place of purchase for a refund or you can request for us to arrange for the pump to be repaired.
3. Faults or losses or failure caused due to but not restricted to any of the following: improper use, improper installation, foreign objects inside the pump or pump controller, normal wear and tear, accidents, misuse, lack of maintenance, not following the installation instructions, damage caused by lightning strike, or power surges, or power spikes or power brownouts, or operating the pump on power other than correct mains power, or operating the pump on power supplied by a domestic generator, power supply of voltage less than 230V, power supply of voltage above 240V - are not covered by warranty. Improper use is defined by us, at our sole discretion.
4. The complete Impeller set (including shaft), Seals and O-rings are all wearing items and therefore are not covered for "normal wear and tear". They are covered by this warranty if they fail due to a manufacturing defect. The Warranty also excludes accidental or deliberate breakages, fading or breakdown due to the effect of exposure to sunlight or chemicals or any other external factor that may affect the life of the product.
5. Warranty will be void if any tampering or removal of identification labels or electrical cables has occurred, or any non-genuine parts have been fitted, or repairs have been carried out by unqualified persons. No warranty applies for goods sold or used for HIRE or RENT or LEASE. No warranty applies, and no liability is accepted, if the pump is used in circumstances that we define as: HAZARDOUS SITUATIONS, MINE SITE, REMOTE AREA, INDUSTRIAL APPLICATION, or any other UNSUITABLE APPLICATION, all of these circumstances are defined by us at our sole discretion.
6. This product is guaranteed as fit for the purpose of pumping CLEAN FRESH WATER for normal domestic household use, and for NO OTHER USE. Performance data quoted is generally from test data and is approximate and does not take into account factors in the installation such as loss of pressure and flow due to pipework & pipe-fittings & valves. It is the purchaser's responsibility to ensure that the product is fit for their purpose and of sufficient size & performance for their application.
7. IMPORTANT: No electrical appliances last forever. Therefore, ALL installations of these pumps and valve-sets supplied by us, must be constructed to allow the owner to easily remove them for servicing, and to easily remove them for replacement, warranty replacement or upgrading. The installation must NOT be constructed in such a manner that specialized tools, or paid tradespersons, or external paid contractors, are required to be engaged in order to remove and/or replace and/or refit the pump, therefore all pumps must be installed using barrel-union connections to facilitate easy servicing or replacement. If the rainwater tank is installed under eaves or other structure such as a deck, ensure that the pump can be easily removed for servicing or repairs. Warranty replacement does not normally include costs of removal and re-installation as we have no control over the method of installation.
8. Before installing or servicing disconnect from the power supply. A ball-valve or gate-valve must be fitted on the suction, and the Town-water backup supply where fitted. A "First-flush-diverter" or similar device must be installed to prevent debris from entering the tank, or a filter screen through which all the incoming water passes before entering the tank. A Y-Strainer or Pre-filter must be installed: (a) For external pumps on the suction (inlet) pipe and (b) For submersible pumps on the discharge before the pump controller (for where there is an external pump controller) - to prevent particles entering the pump and fixtures and fittings including non-return valves. This instruction is a condition of warranty; all warranty is void if this instruction is not followed.
9. This pump is not to be used as your sole water supply. For critical applications where loss of water supply could cause serious consequences, use a DUAL PUMP System so you have a backup water supply or use a TOWN-WATER BACK-UP System.

10. This pump MUST NOT be installed in any manner that if it were to leak or fail to work that it would cause damage or loss to property or persons. It MUST be installed in a well-ventilated and drained area. All warranty is void if this condition is not heeded and no liability can be accepted in the case of damage or loss caused by failing to comply with this condition.

11. The Pump must be connected to a suitable circuit with an integral RCD (safety switch) in the circuit breaker. All warranty is void if this instruction is not followed.

12. RIGHT TO INSPECT: We reserve the right to inspect the product and installation, prior to accepting any warranty claim. We may inspect by use of drone technology, with property owners permission. We also reserve the right to request and require photographs or video evidence in lieu of physical inspection, at our sole discretion. Refusal of inspection cancels all warranty and liability.

13. This warranty does not exclude any non-excludable rights according to Australian Law. However any condition that is made void by Australian Law does not void the remaining conditions, which shall stand unaltered.

14. In the case of a fault, refer to the Trouble Shooting Guide first. If these steps do not rectify the problem, and the fault is due to a manufacturing defect or product failure not caused by improper installation, improper use or lack of maintenance, return the faulty appliance to the original place of purchase with proof of purchase for replacement or refund. Alternatively you can mail us at PO BOX 650 MORNINGSIDE QLD 4170 or send an email to [csv@ascento.com.au](mailto:csv@ascento.com.au) with copy of your purchase receipt, a description of the problem, and your name and address and phone number - we will review your request and send you a replacement directly if we accept your warranty claim. Or call us on 1800 807 604 with the above information; however we will always require a copy of your purchase receipt. If an exact replacement is not available, the closest equivalent product will be supplied at our discretion. Do not send the product to us unless we ask you to do so.

#### **WARRANTY PERIODS DOMESTIC USE;**

REEFE SUBMERSIBLE PRESSURE PUMPS:	2 Years
WaterPro SUBMERSIBLE PRESSURE PUMPS:	2 Years
RainPro Rain-to-Mains Systems:	2 Years
WaterPro Rain-to-Mains Systems:	2 Years

#### **PRIVACY STATEMENT**

We will not use your name, address, phone, or email address for marketing without your express permission. We will not sell or provide it to any other third party for the purpose of marketing.

ASCENTO GROUP AUSTRALIA 37 Export St, Lytton, Brisbane, QLD 4178 | P: 1800 807 604 • E: [csv@ascento.com.au](mailto:csv@ascento.com.au) • W: [www.ascento.com.au](http://www.ascento.com.au)

© COPYRIGHT 2023 No part of this publication is to be copied stored or distributed in any manner or form without the prior written permission of Ascento Group Australia. E&EO.